

# COUNCIL JAMBOREE GUIDE

**2010 National Scout Jamboree**  
**Boy Scouts of America**



**100 YEARS OF SCOUTING**  
*Celebrating the Adventure • Continuing the Journey*

# CONTENTS

---

<b>I. Introduction</b>		<b>V. Program</b>	
Our Strategic Vision . . . . .	1	Jamboree Troop Prejamboree Training . . . . .	14
Our 2010 Mission . . . . .	1	Cooking and Eating at the Jamboree . . . . .	15
Purpose of the Jamboree . . . . .	1	Personal Fitness Training . . . . .	15
Dates and Location . . . . .	1	Jamboree Program . . . . .	15
Attendance . . . . .	1	Gateways . . . . .	15
Work Schedule . . . . .	2	Aquatics Program and Swim Classifications . . . . .	16
		Conservation . . . . .	16
<b>II. Who</b>		<b>VI. Support Services</b>	
Unit Leader Qualifications . . . . .	4	Medical Requirements . . . . .	17
Boy Scout Qualifications . . . . .	4	Insurance . . . . .	17
Youth and Adult Leader Applications . . . . .	4	Transportation . . . . .	18
Scholarship Program . . . . .	5	Military Police and Public Safety Personnel . . . . .	19
Promoting the Jamboree . . . . .	5	Council Caravans . . . . .	19
Council Contingent Coordinator . . . . .	5	Telephone Communications . . . . .	19
Unit Configuration . . . . .	6	Lost and Found . . . . .	19
Staff Qualifications . . . . .	6	Trading Posts . . . . .	20
Youth Staff Opportunities . . . . .	6	Living Quarters Near the Jamboree . . . . .	20
Participant Statement of Understanding and Code of Conduct . . . . .	6	Accommodations at the Jamboree . . . . .	20
Jamboree Staff Clearance Procedure . . . . .	6	Visitors . . . . .	20
2010 National Scout Jamboree Participant Statement of Understanding and Code of Conduct . . . . .	7	Policy on Smoking, Alcohol, or Drugs . . . . .	21
		2010 National Scout Jamboree Staff Statement of Understanding and Code of Conduct . . . . .	22
<b>III. Money</b>		<b>VII. Equipment</b>	
Costs . . . . .	8	Personal Equipment . . . . .	23
Council Quotas . . . . .	8	Patrol Equipment . . . . .	24
Refund Policy . . . . .	8	Troop Equipment . . . . .	25
Council Costs . . . . .	9	Special Notice to All Local Councils . . . . .	25
<b>IV. Organization</b>		<b>VIII. Appendix</b>	
Council Jamboree Committee . . . . .	10	Map of Jamboree Site . . . . .	26
Unit Organization . . . . .	11	Local Council Jamboree Information Sheet . . . . .	27
Jamboree Administration . . . . .	13	Patrol Food Chest . . . . .	28
Jamboree City . . . . .	13	Patrol Table . . . . .	30
Regional Jamboree Coordinator . . . . .	13		
Regional Jamboree Chairman and Commissioner . . . . .	13		
Regional Camp and Subcamp Support . . . . .	13		



100 YEARS OF SCOUTING  
*Celebrating the Adventure ★ Continuing the Journey*

The 2010 National Scout Jamboree logo is the trademark of the Boy Scouts of America and may not be used without the BSA's written permission.



## Our Strategic Vision

“The best, most exciting, fun-filled, safest jamboree ever!”

The 2010 National Scout Jamboree vision statement is designed to provide clarity to goals of the jamboree. It forms a commitment to our Scouts, parents, and chartered organizations of what Scouts expect in a jamboree. This vision statement speaks to the heart of our Scouts and Scouters. It will capture their imagination.

## Our 2010 Mission

The 2010 National Scout Jamboree will:

- Enrich lives of youth participants
- Provide a fun experience
- Showcase Scouting in its 100th year
- Reinforce Scout skills
- Offer innovative programming
- Provide experience in leadership and teamwork
- Offer a diverse, healthy, safe environment where everyone lives the values of the Scout Oath and Law.

The vision statement enables the jamboree executive committee to establish objectives and strategies to deliver a mountaintop experience to Scouts.

## Purpose of the Jamboree

The 2010 National Scout Jamboree provides many unique opportunities for youth and leaders who participate. As you plan and give leadership to this great event, keep in mind the objectives of the jamboree:

- Fun, excitement, and adventure
- Secure environment
- Friendship/fellowship opportunities:
  - With other U.S. Scouts
  - With international Scouts
  - With fellow alumni
- Increased awareness of Scouting:
  - Showcasing Scouting’s ideals, aims, and methods
  - Recruiting and retention benefits (both youth and adults)
  - Projection of Scouting’s image

- Providing a mountaintop experience:
  - Lasting memories
  - Participation in a national signature event
- Individual development (Scout skills and leadership)
- Providing a positive spiritual experience
- Experiencing the diversity of our national and international community
- Providing an expanded awareness of life’s potential
- Experiencing our nation’s history
- Providing opportunities to develop a healthy lifestyle
- Providing opportunities for service to others
- Providing a vision of what youth may become
- Providing opportunities to partner with organizations of like values
- Celebrating the adventure and continuing the journey of our 100th Anniversary

## Dates and Location

The 2010 National Scout Jamboree will be held Monday, July 26, through Wednesday, August 4, 2010, at Fort A.P. Hill, Caroline County, Virginia, which is in the historic area of Washington, D.C., and Williamsburg, Yorktown, Richmond, and Norfolk, Virginia. The opening day will be Tuesday, July 27, and the closing day will be Tuesday, August 3. The jamboree troop arrival day will be Monday, July 26. All troops must be on-site by 4 P.M. Departure day will be Wednesday, August 4. No early departures.

## Attendance

The jamboree is being planned for 35,960 Boy Scouts and unit leaders, plus over 7,500 national, regional, and subcamp staff members. The plan calls for 899 provisional units, with 36 Boy Scouts\* and four unit leaders in each unit.

Regions will allocate council quotas, subject to acceptance by the council. This was completed during the spring of 2008.

\*All references to Boy Scouts or Scouts include Varsity Scouts.

# WORK SCHEDULE

The council must develop a work schedule for local participation in the jamboree. The following will help you get started.

## 2008

<b>Date</b>	<b>Task</b>	<b>Completion Date</b>
April	Appoint staff adviser.	_____
	Select council jamboree chairman.	_____
	Build jamboree committee.	_____
	Develop council fee and payment schedule.	_____
	List prospective adult leaders.	_____
June	Develop plan for recruiting scholarship recipients.	_____
July	Begin promotion in summer camp programs (Scouts and Webelos).	_____
	Submit request for scholarship monies to regional office.	July 31
August	Supply Group projected pricing sent to councils.	August 15
	Start monthly jamboree committee meetings; select adult leaders.	_____
	Adult leadership recruit qualified Scouts.	_____
September	Prepare for district camporee promotions (jamboree adult leaders promote and conduct). Adult leadership recruit qualified Scouts.	_____
October	Monthly jamboree committee meetings.	_____
November	Scholarship application submitted to council service center.	November 1
December	Promote jamboree at roundtables.	_____
	Collect initial jamboree payment.	_____

## 2009

<b>Date</b>	<b>Task</b>	<b>Completion Date</b>
January	Monthly jamboree committee meeting.	_____
	Continue with detailed planning, such as analysis of various tour packages and modes of transportation.	_____
	Finalize collection of initial payments.	_____
	2010 National Scout Jamboree initial reservation fee due at National Council, Jamboree Division, S203.	January 31
February	Begin "wait list" for all jamboree troops of Scouts and leaders. (As life situations change, dropouts may occur.)	_____
	Continue with promotion at roundtables.	_____
	Continue with monthly committee meetings.	_____

.....

2009 *(Continued)*

<b>Date</b>	<b>Task</b>	<b>Completion Date</b>
March–May	Camporee promotion. Supply Group equipment catalog available. All participants need physical within one year of jamboree.	_____ _____ _____
June–August	Begin promotion in summer camp programs (Scouts and Webelos). Finalize collection of second jamboree fee payment. Second reservation fee due at National Council, Jamboree Division, S203. Note: Early-bird fee is due or add \$50 per participant if not paid by the July 31, 2009, due date.	_____ _____ _____
September	Continue with monthly committee meetings. Order equipment from Supply Group.	_____ _____
December	Continue with promotion effort.	_____

2010

<b>Date</b>	<b>Task</b>	<b>Completion Date</b>
January	Complete collection of final fees. Check all transportation and tour plans. Final reservation fee due at National Council, Jamboree Division, S203. Note: Full payment is due, or add \$50 per participant if not paid by the January 31, 2010, due date. Supply Group jamboree items for sale online to participants and staff (equipment, souvenirs, and uniforms available).	_____ _____ _____
February	Submit national tour permit to region.	February 27 _____
March–April	Conduct second meeting of jamboree troop(s).	_____
May	Conduct third meeting of jamboree troop(s).	_____
May–June	Conduct prejamboree training weekend.	_____
July–August	Attend 17th National Scout Jamboree.	July 26 to August 4 _____
September	Final jamboree committee meeting.	_____
November	Have a jamboree reunion.	_____



### Unit Leader Qualifications

#### Scoutmaster

- Have served as a Scoutmaster for at least one year during the three-year period prior to July 1, 2010.
- Completed basic Scoutmaster training or Boy Scout Fast Start and *Scoutmaster and Assistant Scoutmaster Leader Specific Training*, No. 34879.
- Completion of Wood Badge for the 21st Century.
- Be able to serve as a role model of physical fitness. Have participated in the prejangboree training experience.
- Have filed a Jamboree Personal Health and Medical Record, Class 3, No. 67-34412, before the prejangboree training with the council jamboree committee.
- Complete the 60-minute Youth Protection Training.
- Be approved by the local council.
- Although not required, Scouter's Key is a desirable qualification.

#### First Assistant Scoutmaster

(Same qualifications as Scoutmaster)

#### Second Assistant Scoutmaster

- Be at least 21 years of age by July 1, 2010.
- Complete the appropriate leader-specific training.
- Have served actively in an adult troop leadership position for at least one year during the three-year period prior to July 1, 2010.
- Have participated in the prejangboree training experience.
- Have filed a Personal Health and Medical Record, Class 3, No. 67-34412, before the prejangboree training with the council jamboree committee.
- Complete the 60-minute Youth Protection Training.
- Be approved by the local council.
- Be able to serve as a role model of physical fitness.

#### Third Assistant Scoutmaster

- Be at least 18 years of age (but not yet 21) by September 1, 2010.
- Have served actively in a troop leadership position.
- Complete the appropriate leader specific training.
- Have participated in the prejangboree training experience.

- Have filed a Personal Health and Medical Record, Class 3, No. 67-34412, before the prejangboree training with the council jamboree committee.
- Complete the 60-minute Youth Protection training.
- Be approved by the local council.
- Be able to serve as a role model of physical fitness.

### Boy Scout Qualifications

Scouts who participate in the 2010 jamboree are selected by the more than 300 local councils. Each Scout must

- Be at least a First Class Scout.
- Have completed sixth grade *or* be at least 12 years of age by July 1, 2010, and have not reached his 18th birthday by August 3, 2010.
- Participate in the prejangboree training experience.
- Have filed a Personal Health and Medical Record Form, Class 3, No. 67-34412, before the prejangboree training.
- Have been active in a troop or team for at least six months prior to July 1, 2010.
- Be approved by his Scoutmaster or Varsity Scout Coach.
- Be approved by the local council jamboree committee.

### Youth and Adult Leader Applications

In order to be complete, each council must develop its own Local Council Jamboree Information Sheet to insert in the two-page forms. A sample is shown in the appendix on page 29. The applications may be downloaded from [www.scouting.org/jamboree](http://www.scouting.org/jamboree).

Youth and adult leaders must complete an online application. It is accessed through [www.scouting.org](http://www.scouting.org) for non-BSA employees. BSA employees will access it through [www.myBSA.org](http://www.myBSA.org). Applicants will need to use their BSA ID number or their Social Security number to access the application Web site.

The individual will be directed to print a confirmation and send it to the council with a \$100 deposit.

Councils will be provided instruction on accessing the registration reports in a special announcement. The Web site will be activated in May 2008.

## Scholarship Program

Councils are urged to include in their planning the importance of having representative jamboree units. These units should take into account all race, ethnic, religious, and economic conditions present in the population groups in the territory served by the council. Local support is frequently available to provide scholarships for youth who might not otherwise be able to attend the national jamboree. An orderly plan should be developed to accommodate needy participants. This plan should include:

- A goal for representative participation
- Requirements for scholarship aid
- Degrees of aid from partial to full scholarship (including uniform and equipment needs)
- Scholarship fund-raising plan
- List of selective prospects for funding
- Clearing and coordinating prospects with finance committee
- Jamboree scholarship fund-raising team (must follow guidelines of BSA fund-raising)

Prospective sources of funds may be found in service clubs, civic clubs, chartered organizations, corporations, foundations, and selected major contributors. Information to assist your committee may be found in:

- *Guidelines on Product Sales and Policy Issues*, No. 35-373
- *Foundation Resource Manual*, No. 35-530
- *Project Sales Manual*, No. 35-603

## Promoting the Jamboree

Appointment of the council jamboree committee should be a top priority, followed by the selection of your unit leaders.

Jamboree unit leaders and council jamboree committee members should then be organized into recruiting teams to visit each troop and promote attendance. Set up a troop rally and invite parents.

Show the jamboree audiovisual and pass out the jamboree promotion brochure. Each jamboree troop leader should be asked to participate in the recruiting of Scouts for the jamboree.

Each jamboree unit leader should have applications, fliers, and the Local Council Jamboree Information Sheet describing the tour plan, cost, and payment schedule.

Recruiters should confer with Scouters of all troops and Varsity teams in the council to prepare a prospect list. It is important that the unit leader not say “no” for any youth or parents.

A jamboree rally should be a must in every district in order to tell the jamboree story to youth and their parents.

Conduct an active publicity campaign on the jamboree, particularly among youth members, parents, leaders, and chartered organizations. Use the council news bulletin, council Web site, executive board meetings, roundtables, troop committee meetings, and unit meetings for a presentation or a short talk on the jamboree. Provide material to your local newspapers, radio and television stations, and other media outlets in your area.

Start a news and feature story campaign—appointment of chairman and committee, selection of leaders, approval of Scout participants—to local news media.

Other suggestions for promoting the jamboree include the following:

- Have a jamboree reunion for the adults and youth who have attended previous jamborees, providing a “reserve” of enthusiastic salespeople.
- Tie in jamboree promotion with your summer camp with posters, displays, fliers, and applications, including someone who can talk authoritatively about the jamboree. Show the jamboree audiovisual each week so that every Scout and leader in camp knows about the jamboree.
- Include the jamboree in council shows, camporees, and all other council and district events.

## Council Contingent Coordinator

When the council contingent consists of three or more troops, the council will be expected to have a professional staff member or a key volunteer travel with the contingent as the **council contingent coordinator**. **This person must file a jamboree staff application** and pay the national jamboree fee. The application should list his/her position as council contingent coordinator and note that he/she is available for assignment to the jamboree staff. The regional jamboree coordinator will assign that person to a staff position on the subcamp or regional jamboree staff. When the council contingent consists of less than three units, the council may name one of the unit leaders to act as the contingent coordinator. The council contingent coordinator is the person to whom jamboree unit leaders can turn for help in solving problems en route to and from the jamboree. Each council should provide its region with a staff adviser’s name and e-mail address to aid communication.

## Unit Configuration

Councils must adhere to a troop size consisting of 36 youth and four leaders. The 40-person troop is ideal for feeding four patrols of 10 individuals—nine Scouts plus one leader. It is also perfect for tentage in multiples of two Scouts per tent and for most tour buses that are 40 passengers in size. Finally, each troop site in the subcamps is designed to house 40 Scouts and leaders.

## Staff Qualifications

Jamboree staff positions are open to adult men and women who meet required qualifications. Adult staff members must have been born before July 26, 1989. Youth staff members must have been born between August 4, 1989 and July 26, 1994, and be registered members of the Boy Scouts of America. Jamboree staff applicants are submitted online directly to the national office. An electronic process is being developed for councils' review, evaluation, and approval. The Web site will be accessible through [www.scouting.org](http://www.scouting.org) for volunteers. BSA employees may access it through [www.myBSA.org](http://www.myBSA.org). The Web site launch date is June 2008.

## Youth Staff Opportunities

Youth staff (under age 18) have the opportunity to serve in numerous job assignments at the jamboree. Youth staff will be needed in many of the jamboree groups and services listed on the staff application, such as jamboree band (Daily Ceremonies), Trading Posts, Brownsea Island, Action Centers, and Service Corps.

## Participant Statement of Understanding and Code of Conduct

The participant Statement of Understanding and Code of Conduct for the 2010 National Scout Jamboree will accompany applications for all Scouts and leaders. Youth and adult staff members will receive a copy of the staff Statement of Understanding and Code of Conduct on their staff letter of appointment when they are selected to serve. In all instances, the signature by participants, parents or guardian, and staff on either the participant application or staff letter of appointment dictates agreement to abide by the Code of Conduct and Statement of Understanding.

## Jamboree Staff Clearance Procedure

The procedure for handling staff recruitment is as follows:

- The home council evaluates and approves applicant's qualifications.
- The region reviews applicant and approves or rejects.
- Approved staff applications are routed to directors for selection.
- When selected, the prospective staff member is offered a position.

The electronic online application will emphasize that the offer to apply **does not** guarantee a staff position. Local councils determine who may participate at a national Scout jamboree. There will be a nonrefundable application fee. Once the application is fully approved, it will be offered to the staff director of the applicant's first preference as indicated on the application.

There will be *no exceptions* to these procedures.

The staff application includes a section for the applicant to list in order of preference five staff positions he or she would like to work at the jamboree. Every effort will be made to assign individuals to the staff group of their choice. Under no circumstances should any individual be promised a staff position until their application has the approval of their council and region and the national office.



## Participant Statement of Understanding and Code of Conduct

**Statement of Understanding:** All participants (Scouts and leaders) are selected to represent their local councils based on their qualifications in character, camping skills, physical and personal fitness, and leadership qualities. Therefore, all adult and youth participants and their parents or guardians are asked to read the Code of Conduct and Statement of Understanding as a condition of participation. It is with the further understanding that serious misconduct or infraction of rules and regulations may result in expulsion, at the participant's expense, from the jamboree or during the jamboree tour. Ultimately, we want each participant to be responsible for his or her own behavior, and only when necessary will the procedure be invoked to send a participant home from the jamboree.

**All youth and adult participants are expected to abide by the Code of Conduct as follows:**

1. The unit's adult leaders (Scoutmaster and assistants) are responsible for the supervision of its membership in respect to maintaining discipline, security, and the jamboree Code of Conduct.
2. The Scout Oath and Law will be my guide throughout the jamboree.
3. I will set a good example by keeping myself neatly dressed and presentable. (The official Scout uniform and jamboree identifying items are the only acceptable apparel.)
4. I will attend all scheduled programs and participate as required in cooperation with other unit members and leaders.
5. In consideration of other unit participants, I agree to follow the bedtime and sleep schedule of the unit, unless otherwise directed by the jamboree program.
6. I will be responsible for keeping my tent and personal gear labeled, clean, and neat. I will adhere to all jamboree recycling policies and regulations. I will do my share to prevent littering of the jamboree grounds.
7. I understand that the purchase, possession, or consumption of alcoholic beverages or illegal drugs by any youth member is prohibited. This standard shall apply to all participants—both youth and unit leaders.
8. Serious and/or repetitive behavior violations by youth, including use of tobacco, cheating, stealing, dishonesty, swearing, fighting, and cursing, may result in expulsion from the jamboree or serious disciplinary action and loss of privileges. The jamboree director *must be contacted* for the expulsion procedure to be invoked. *There are no exceptions.*
9. I understand that gambling of any form is prohibited.
10. I understand that possession of lasers of any type, and possession or detonation of fireworks is prohibited.
11. I will demonstrate respect for unit and jamboree property and be personally responsible for any loss, breakage, or vandalism of property as a result of my actions.
12. Neither the unit leader nor the Jamboree Division of the BSA will be responsible for loss, breakage, or theft of personal items. I will label all my personal items and check items of value at the direction of unit leaders. Theft will be grounds for expulsion.
13. While participating in the action centers, aquatics, and other activities, I will obey the safety rules and instructions of all supervisors and staff members.
14. In accordance with U.S., local and state laws, adult leaders and youth are prohibited from having firearms and weapons in their possession.
15. Scoutmasters and assistants will be guided by the Scout Oath and Scout Law and will obey all U.S., local, and state laws.
16. Scoutmasters and assistants must receive Youth Protection training and follow the guidelines therein prior to prejamboree training.
17. Hazing has no place in Scouting. Nor do running the gauntlet, belt lines, or similar physical punishment. Leaders and older youth must prevent any youth from being "initiated" into the troop with hazing.
18. Adult leaders should have the good judgment to avoid trading souvenirs or patches with a child or youth member in Scouting. Youth members may trade with youth members. Adult leaders may trade only with other adults 18 years of age or older.
19. Adult leaders and youth leaders must instruct youth to avoid confrontation with groups, demonstrators, or hecklers and must assume a passive reaction to name-calling from individuals or groups. Units or groups must be removed from the area of potential conflict immediately.
20. Serious violation of this code may result in expulsion from the jamboree at the participant's own expense. All decisions will be final.



## Costs

The total national fee for the nine days at the jamboree will be based on facilities, food, supplies, and program material. It is \$795.

The national reservation fee will be \$100. Councils will be billed for this fee based on their agreed upon quota.

The national schedule of fee payments is:

- Before January 31, 2009, \$100 reservation fee per person  $\times$  council's quota (nonrefundable and nontransferable to pay the balance of fees due)
- Before July 31, 2009—\$400
- Before January 31, 2010—\$295

Approximately one month prior to payment due dates, councils will receive a billing for their contingent payment. Before February 28, 2010, the council must supply the national Jamboree Registration Service with a complete roster of all unit participants. **Note:** Scholarships, if applicable, will be deducted from the council's final payment, due January 31, 2010.

The council's fee payment schedule should be at least one month ahead of the national schedule and the fees will, of course, be more than the national fee. The council fees need to reflect the total cost of the council's plans, including equipment and tours.

## Council Quotas

Orders for troop food and equipment to be used at the jamboree must be placed well in advance of the actual event. To do this, the national office must rely on the council quota to determine the quantities needed.

Regions will determine the council's quota, subject to acceptance by the council. Acceptance of this quota constitutes a council's commitment to pay a \$100 reservation fee, based on its quota, for each youth and leader.

To change a council quota (plus or minus), a written request must first be approved by the council's regional coordinator and the Jamboree Division at the national office prior to January 31, 2010.

## Refund Policy

### National

This refund policy relates to the transmittal of funds between local councils and the national Jamboree Registration Service for troop participants.

1. The national reservation fee of \$100 is nonrefundable and is nontransferable to pay the balance of any fees due.
2. Any refund requested by local councils must be in writing and must be approved by the Scout executive. Before January 31, 2010, refunds will be made as follows. Additional fee payment, less the \$100 reservation fee, will be refunded in full.

After January 31, 2010, refunds will be made to local councils upon receipt of written notice of cancellation approved by the Scout executive. Refunds will include total amount paid, *less the administrative charge of \$75, the reservation fee of \$100, and other expenses related to contractual agreements made on behalf of local council jamboree participants. The national office does not refund the reservation fee to participants.*

3. Monies, subject to refund, may be applied to the final payment of the national jamboree fee, providing documentation is provided in advance.
4. Following the jamboree, no refunds will be made.

### Local Council

This refund policy relates to the transmittal of funds between the local council and troop participants.

1. The national reservation fee is not refundable.
2. There will be no refund following the jamboree.
3. A clear statement of the council's refund policy needs to be a part of the Local Council Jamboree Information Sheet.

Local councils should use the following steps when a jamboree participant requests a refund:

- a. The council asks the Scout or leader to submit a written request for a refund to the council jamboree committee.
- b. Based on the Local Council Refund Policy listed on the Local Council Jamboree Information Sheet, the local council is authorized to make the refund.

4. The following is a suggested refund statement:
  - a. If you sign up for the jamboree and find that you cannot attend, you will receive a full refund from the local council only if there is an alternate\* to take your place.
  - b. If there is no alternate, a partial refund will be made. This includes the fees you have paid to date, less expenses related to contractual agreements made on your behalf.
  - c. Deposit fees paid by alternates not selected as active participants will be refunded in full.

## **Council Costs**

In addition to the national jamboree fee, the council should develop its own costs covering the following items:

- Transportation
- Meals and lodging en route to and from the jamboree
- Pre- and post-jamboree trips and tours
- Prejamboree training
- Promotion
- Unit equipment
- Contingency
- Leadership

---

*\*An alternate may be selected from the council waiting list, if there is one, or could be a properly qualified youth recruited by the person requesting a refund.*



## Council Jamboree Committee

Through the careful selection of its council jamboree committee, the council can do a great deal to ensure its youth and leaders a beneficial jamboree experience.

All of the following titles must be filled to allow for effective administration of jamboree operations. Large councils will need the full organization, plus additional personnel for some of the subcommittees. A smaller council may combine some of the duties. Regardless of council size, all of these functions must be carried out.

### Jamboree Committee Chairman

- Appointed by the council president.
- Selects, recruits, and officially appoints all committee members and assigns responsibilities.
- Coordinates and stimulates action of the committee.
- Informs council executive board on progress.

### Professional Staff Adviser

- Appointed by the Scout executive.
- Coordinates jamboree troop promotion and preparation, and works with the jamboree committee chair.

### Promotion

- Coordinates promotional efforts and plans.
- Works to ensure the representativeness of the contingent from the council. Recruits the personnel needed to do the job of “providing an opportunity for every youth who wishes to take part in the jamboree.”
- Conducts jamboree promotion rallies in each district in the spring and fall.
- Works with jamboree unit leaders to promote the jamboree.
- Works with public relations subcommittee to draw up and implement a council jamboree public relations plan.
- Secures community resources.

### Transportation

- Develops complete transportation plans for the council contingent.
- Develops tours before and/or after the jamboree for the council jamboree contingent.
- Advises jamboree transportation service on arrival and departure date and time on proper form.

### Personnel

- Selects—subject to approval of the council jamboree committee—the jamboree troop leaders needed for the council’s jamboree troops. Preference should be given to those who have not attended a jamboree; only in exceptional cases (specialized skills) should those who have attended two times previously be considered.
- Responsible for screening and qualifying all jamboree participants, including applicants for national staff positions.

### Equipment

- Approves equipment to be sure that it meets the jamboree standards.
- Determines the equipment needs for the council jamboree troops and supervises the ordering of this equipment (Supply Group package plan is recommended).
- Supervises disposal of equipment after the jamboree.

### Health and Safety

- Sees that all medical forms for jamboree participation are approved, signed, and transmitted.
- Checks all tour plans and tour permit applications carefully to see that they are adequate to protect the health and safety of participants.
- Physical fitness must be a consideration when approving jamboree leaders and staff. (Climate conditions in Virginia are hot and humid.)

### Training

- Develops plans for and conducts the prejamboree training with other members of this subcommittee using the prejamboree training outline.
- Coordinates with the region to ensure plans are complete.

### Public Relations

- Works with the promotion subcommittee chairman to draw up and implement a council jamboree public-relations plan.
- Recruits and trains youth jamboree news correspondents.

## Unit Organization

### The Method

The patrol will be the functioning unit at the jamboree. Patrols formed into units under able adult leaders will be the jamboree pattern or organization.

Duties of the troop staff are:

#### Scoutmaster\*

- Serves as the executive officer of the troop.
- Maintains policies and coordinates efforts of assistant Scoutmasters.
- Assists in conducting jamboree promotion rallies and in recruiting individual Scouts to attend the jamboree.
- Leads his participants in prejamboree training.
- Works through his assistant Scoutmasters, senior patrol leader, and patrol leaders to ensure fulfillment of their duties.
- Accompanies his troop to and from the jamboree.
- Does not move his troop outside the bounds of his subcamp except upon approval received from the subcamp director.
- Is personally responsible for the health, safety, and morale of his troop.
- By his example, serves as a role model for others to follow.
- Is responsible at all times for the proper behavior and conduct of the members of his troop.
- Receives a report from his senior patrol leader on bed check each evening after taps and reports those present, accounted for, or missing to the designated subcamp staff member.
- Cooperates with subcamp leadership at all times.

The personal leadership of the Scoutmaster is one of the most important factors in effective administration of the jamboree. Good judgment and sensible controls will help make many camp regulations unnecessary.

#### First Assistant Scoutmaster (Troop Activities)

- Serves as the troop leader in the absence of the Scoutmaster.
- Assists in conducting jamboree promotion rallies and in recruiting individual Scouts to attend the jamboree.
- Participates in prejamboree training.
- Works with the assistant senior patrol leader in administering troop operations.

- Is responsible to the Scoutmaster for program and activities of the troop, including pageants, campfires.

#### Second Assistant Scoutmaster (Physical Arrangements)

- Assists in conducting jamboree promotion rallies and in recruiting individual Scouts to attend the jamboree.
- Participates in prejamboree training.
- Responsible to the Scoutmaster for troop physical arrangements.
- Works with the troop quartermaster in the issuance of supplies.
- Arranges directly with the subcamp equipment and maintenance officer for supplies.
- Working through and with the quartermaster and patrol leaders, trains and oversees the patrols in their tasks of drawing food and food supplies, preparation and serving of food, and cleaning up.
- Consults regularly with patrol cooks on the most effective ways to prepare daily food selections.
- Meets daily with the patrol cooks and firemen, giving briefings on food preparation and safety precautions.
- Oversees cleanup operations after each meal.
- Is responsible for the care and neat appearance of all equipment.
- Is responsible for transportation of personal baggage to and from the jamboree.

#### Third Assistant Scoutmaster (Scheduling and Records)

- Assists in conducting jamboree promotion rallies and in recruiting individual Scouts to attend the jamboree.
- Participates in prejamboree training.
- Works with the troop scribe in the handling of troop records and the scheduling of troop participation in jamboree activities.
- Contacts the subcamp activities director in handling routine matters.
- Encourages Scout news correspondents to send news to their hometowns.
- Maintains liaison with subcamp communications officer.
- Responsible for troop first aid and contacts the subcamp medical officer on serious cases.
- Maintains general morale of troop, including distribution of mail and other communications.
- Cares for troop exhibits.

---

\*Member of the patrol leaders' council

### **Senior Patrol Leader\***

- Leads patrol leaders' council.
- Serves as the top boy leader of his troop.
- Maintains information on the whereabouts of troop members.
- Works directly with the Scoutmaster in administering troop operations.
- Through the patrol leaders, is responsible for the appearance of Scouts with regard to cleanliness and proper uniforming.
- Maintains schedules within the troop camp covering reveille, meal hours, and other special assignments received from subcamp directors.
- Organizes all formations of the troop.
- Makes bed check at taps each evening and reports and accounts for all members of the troop to the Scoutmaster.

### **Assistant Senior Patrol Leader\***

- Acts in the absence of the senior patrol leader and assists the senior patrol leader as directed.
- Works with the first assistant Scoutmaster in administering troop activities and participation in campwide events.

### **Quartermaster\***

- Is responsible for troop equipment and supplies.
- Works with the second assistant Scoutmaster for storage and issuance of all equipment and supplies belonging to the troop or issued to it at the jamboree.
- Maintains an inventory of all equipment and supplies, and is responsible through the second assistant Scoutmaster for the return in good repair of all equipment to the subcamp equipment and maintenance officer and to the local council.

### **Scribe\***

- Is the custodian of all troop records.
- Works directly with the third assistant Scoutmaster in handling registration procedures and in keeping such records as required.
- Keeps the log of the troop and carries out other duties as may be assigned to him by the Scoutmaster.
- Assists the third assistant Scoutmaster in registering and helping Scout news correspondents.

### **Chaplain Aide**

- Helps with troop program planning, considering religious holidays and including religious observances during troop activities such as the jamboree troop campout and traveling to and from the jamboree.
- Assists in planning and carrying out troop religious activities.
- Tells troop members about the religious emblem program of their faith and how to earn one.
- Encourages troop members to live up to the ideals of the Scout Oath and Law and the Scout slogan.

### **Historian**

- Takes care of troop trophies and keepsakes.
- Keeps a logbook about the troop's meetings and activities.
- Keeps a scrapbook of newspaper clippings and other items about the troop's activities.
- Collects photographs from other troop members to make photo album of the troop's activities.

### **Patrol Leader\***

- Represents his patrol as a member of the patrol leaders' council.
- Receives assignments for patrol members from his troop leaders.
- Informs members of his patrol of assignments and sees that they are carried out.
- Sees that patrol tents, equipment, and the area around the tents are kept neat, clean, and orderly.
- Knows the whereabouts of every member of his patrol.
- Gets his patrol to the point where the troop is forming and—when called upon by the senior patrol leader—reports and accounts for his full membership.

### **Assistant Patrol Leader**

- Acts in the absence of the patrol leader.
- Assists the patrol leader as directed.

### **Boy Scouts**

Conduct themselves in strict accordance with the Scout Oath and Law, ensuring an excellent camp, splendid commendation from the public, and a good time for every Boy Scout and Scouter.

---

\*Member of the patrol leaders' council

## **Jamboree Administration**

To plan and conduct a national Scout jamboree, an executive committee of key national volunteers is selected two to three years prior to the event by the president of the Boy Scouts of America.

In addition to the overall chairman/camp chief, six individuals have the ultimate responsibility for conducting the 2010 National Scout Jamboree. They are supported by a national staff adviser for each of the six groups.

These six groups are Administration, Media and Corporate Alliance, Enterprise Risk Management, Food Service, Retail, and Program and Regional Support.

The groups are further divided into various services. For example, the Food Service Group has a Subcamp Food Service to handle all troop participant feeding and regional headquarters and subcamp staff dining. Staff Food Service provides dining hall meals for the jamboree central staff. Finally, a Special Food Service assists in kosher meals, ice distribution, and other special requests.

The four regions of the Boy Scouts of America provide all staff for subcamp and action center operations. Regional coordinators interface with the Subcamp Operations Division of the Program and Regional Support Group.

To operate these many services, there is a need for 7,000 volunteer and professional Scouters and nearly 2,300 active-duty and reserve military and civilian personnel working in concert with the Boy Scouts of America for 2010.

## **Jamboree City**

The 2010 National Scout Jamboree will attract thousands of Scouts and leaders, and while it won't be the biggest city in Virginia, it will be the fastest growing on the day of arrival—July 26, 2010! Imagine 18,000 tents and 3,600 patrol kitchens popping up in a matter of hours.

Amid the thousands of colorful tents that will house participants and provide program and support services, there is an infrastructure that provides a secure environment at Fort A.P. Hill. Everything from bus and telephone systems to a hospital and first-aid stations, police and fire departments, post offices, food warehouses, a daily newspaper, and retail stores (trading posts) provide all the support and program services needed for this outstanding event.

## **Regional Jamboree Coordinator**

Each region has appointed a member of the regional staff to serve as regional jamboree coordinator. They are there to assist you in any phase of the jamboree. Call upon them for any assistance you may need.

## **Regional Jamboree Chairman and Commissioner**

Each region has also appointed a regional jamboree chairman and commissioner and committee that can be called on for assistance through your regional jamboree coordinator.

## **Regional Camp and Subcamp Support**

There will be four regional camps and 21 subcamps. A volunteer and professional team will direct each regional camp and subcamp. Volunteers will serve as the regional camp chief and regional commissioners. The regional director will be the regional camp director. The regional subcamp director will be a professional staff member, and the regional subcamp chief and commissioners will be volunteers.

Two assistant directors will serve on the subcamp staff, sharing the responsibility for a number of key camp services. Support will be provided by camp commissioners appointed by the camp director.

The guiding principle of subcamp staff operations is to ensure a rewarding experience for each participant. This will govern all actions related to the staff responsibility for the conduct of the overall jamboree program and support services.



## Jamboree Troop Prejamboree Training

Prejamboree training for Scouts and leaders will be conducted by the council jamboree committee and jamboree unit leaders under the direction of the council jamboree training chairman. When there is a multicouncil troop, the region will assign the training responsibility.

It is recommended that the training be held in May or June 2010. It will include:

- Camping three days and two nights (48 hours).
- Setting up troop sites by jamboree standards.
- Using the equipment that will be used at the jamboree.
- Practicing camping and cooking skills of the type scheduled for the jamboree.
- Practicing activities and contests related to the jamboree.

The training plan should be adapted to local conditions.

The prejamboree training experience provides for members of council provisional units to get acquainted and—if not done previously—elect their leaders and prepare youth and adults for a happy, safe, and healthy jamboree.

The training objectives are:

- To prepare Scouts and leaders to derive maximum benefits from the jamboree and to stimulate them to spread the jamboree spirit and skills when they return home.
- To emphasize the place of the Scout Oath and Scout Law at the jamboree.
- To strengthen the patrol method. The patrol will be the functional unit at the jamboree.
- To emphasize the importance of youth leadership within the unit.
- To preview jamboree program activities and prepare Scouts for participation.
- To provide an opportunity for checking troop equipment and personal gear.
- To practice jamboree-style camping and cooking skills.
- The *Jamboree Troop Leader Guide*, No. 67-155, will include the following:
  - Personal Information.** Health, equipment, safety, Scouting skills, Scouting ideals, and leadership responsibility
  - Troop Help.** Troop organization, equipment, program, and patrol equipment; food (receiving, storage, preparation, and consumption); sanitation (disposal

of waste, general cleanliness); tentage, bedding, and daily routine

- Jamboree Program.** Opportunities for demonstration and participation, special activities, camp events, schedule of jamboree, travel information, and conduct and activities en route

Copies of the *Jamboree Troop Leader Guide* will be available to local councils no later than April 2009. This will be available only by downloading from [www.scouting.org/jamboree](http://www.scouting.org/jamboree).

The idea for the prejamboree training troop campout is to have fun while getting ready for the jamboree!

The need is for the new troop of seasoned campers to get to know their buddies better. So, keep a cheerful spirit, even when working hard, and make this special campout a meaningful experience. Success in molding this troop into a well-functioning unit will directly affect the kind of experience these Scouts will have on the jamboree site.

Council jamboree committee members and assigned staff members will meet with and train jamboree troop leaders and also plan the jamboree troop campout. The *Jamboree Troop Leader Guide* will serve as the basic text for these training sessions.

Troop leaders will meet with and train the following youth leaders, who will be selected by the Scoutmaster in consultation with the assistant Scoutmasters: senior patrol leader, assistant senior patrol leader, quartermaster, and scribe. This training is to consist of leader skills and preparation for the jamboree unit campout.

The entire unit will come together for the campout at a time and place selected by the council jamboree committee. This may be in cooperation with other councils, may include other jamboree units, or be a single troop experience. The three-day program contained in the guide must be followed closely so that all jamboree participants arrive at the site ready to go.

The campout should be scheduled in June and preferably would begin Friday afternoon and end Sunday afternoon.

Following the campout, unit leaders will continue informal training of all troop youth leaders.

The *Jamboree Troop Leader Guide* will contain information that should be shared during the campout. Every adult leader should be familiar with its content.

## Cooking and Eating at the Jamboree

The success of the jamboree will be determined to a great extent by the quality and quantity of meals that are served.

Food issued to participants will be of top quality, and there will be lots of it, too! Proper training of patrols, prior to and during the jamboree, in food preparation techniques will help to ensure an enjoyable experience for all troop members.

It is the responsibility of the assistant Scoutmaster in charge of physical arrangements to give oversight to the preparation and distribution of meals within each of the patrols. His duties will include:

1. Working through and with the senior patrol leader, quartermaster, and patrol leaders, training and overseeing the patrols in their tasks of drawing food and food supplies, food preparation, serving, and cleanup.
2. Consulting with patrol cooks regularly on the most effective ways to prepare daily food selections.
3. Meeting with the patrol cooks, giving briefings on food preparation and safety precautions.
4. Overseeing cleanup operations after each meal.

### Menu Booklet

On the opening day of the jamboree, each patrol will receive a printed menu booklet containing general instructions on patrol cooking for all 27 jamboree meals. The booklet will provide instructions on the cooking and serving of food, and job descriptions for cooks and camp cleaners. It is important that the assistant Scoutmaster in charge of physical arrangements meets daily with the head cooks and assistant cooks of each patrol to review the day's menu and related food preparation instructions.

### Cooking

In an effort to reduce meal preparation time, provide more time for program, as well as to ensure hot food is provided in case of inclement weather, cooking will be done on propane appliances.

The patrol equipment package made available by the Supply Group will include two two-burner camp stoves with the fittings necessary to use the fuel supply furnished at the jamboree. We strongly recommend that you acquire this package for your patrols so you will be assured of having equipment that will coordinate with the fuel tanks and supplies furnished by the jamboree. Tanks and fuel will be supplied at the jamboree in quantities sufficient for all meal preparation. UNDER NO CIRCUMSTANCES ARE YOU TO BRING FUEL TANKS OR A FUEL SUPPLY.

Patrols may bring propane camp stoves (without fuel tanks) other than those in the official patrol equipment package. They must be a recognized commercial brand and they will be inspected and certified by jamboree officials before you may use them. **HOMEMADE STOVES OR HOME-RIGGED STOVES WILL NOT BE ALLOWED.** Appropriate fittings and hoses for use with a 20-pound tank must accompany these stoves.

## Personal Fitness Training

The primary means of transportation at the jamboree is walking. During the course of the day, Scouts and leaders will average 10 miles.

It is strongly recommended that all participants and leaders physically prepare themselves with an exercise and walking routine prior to the jamboree. An excellent approach would be to earn or re-earn Hiking, Swimming, Personal Fitness, Sports, Cycling, or Rowing merit badges. Just walking an hour a day will do wonders to prepare Scouts and leaders prior to the jamboree.

## Jamboree Program

The Scouting program will be a feature at the 2010 National Scout Jamboree, highlighted by the skills of Boy Scouting, reliving the nation's heritage, physical fitness, conservation, ecology, and the spirit of brotherhood. Daily activities will offer fun, challenge, an opportunity for religious reflections, citizenship, and the international brotherhood of being with Scouts from other countries of the world. Patrol and individual competitive events will be carried out on a troop and subcamp level.

New methods of practicing and demonstrating skills will be an important part of the jamboree. The skills will include archery, orienteering, challenge trails, marksmanship, boating, canoeing, hunter safety, as well as updated versions of the disabilities awareness trail, competitive events, merit badge midway, and the arts and science fair.

Scouts will meet together in troop, intertroop, subcamp and region campfires, and at the big, colorful, fabulous arena show.

The *Jamboree Troop Leader Guide* will be made available to jamboree unit leaders to assist them in their planning.

## Gateways

Jamborees stir color and excitement, and troop gateways have always played a big part in this. Showing Scouts from other parts of the country and other parts of the world what's unique or interesting about a troop's home area is a

time-honored jamboree tradition, and gateways are one of the most visible ways to do that. Troops usually design their gateways to reflect the most notable aspects of their home area—history, geography, industry, etc. This is often done in very creative and novel ways.

Designing and building the troop gateway is just one more area where it is extremely important to plan ahead. To ensure that all the materials, tools, and equipment for a gateway will be available when and where they are needed, it is vital that plans be made early to transport everything along with the council contingent. The jamboree site is rural and relatively remote, and once there, obtaining even the simplest of tools or materials could be a real headache. **Due to security policies of the U.S. Army and Fort A.P. Hill, separate shipment of materials or equipment to the jamboree will not be accepted. Everything must be transported with the council contingent.**

**No Holes!** Federal authorities have prohibited the digging of holes of any kind, for any purpose, anywhere on the jamboree site without prior written permit. This rule will be strictly enforced. Applications for permits to dig holes for gateways will not be considered. **There will be new height and material restrictions for all gateways. The new standard will be released in April 2009.** All gateways must be designed to support themselves on the ground surface, and be secured only by means of weights, staked guy lines, or other means not requiring holes in the ground. Storms are common at jamborees, and gateways should be designed to accommodate winds up to 70 miles per hour. It is highly recommended that troops design, fabricate, erect, and test gateways prior to transporting them to the jamboree site. (Please see “Special Notice to All Local Councils” on page 27.)

## Aquatics Program and Swim Classifications

The jamboree will feature several aquatics activities. Canoeing, board sailing, and rafting are the major items being considered at this point. It will be required for each participant to be classified for swimming ability before coming to the jamboree. These classifications are nonswimmer, beginner, and swimmer. Jamboree Scoutmasters are responsible for swim classification checks and issuing buddy tags to their Scouts during the scheduled jamboree troop campout (prejamboree training). Each tag will be marked with the Scout’s name and swim classification. Correct certification by Scoutmasters is a serious trust, since the life of a boy could depend on it. A single buddy tag is issued by the Scoutmaster to each Scout. This tag will be used for the supervised aquatic activities and must be presented by the Scout when he arrives at the waterfront area. If he does not have a tag, he will be treated as a nonswimmer.

## Conservation

Because plants and plant products can carry insects or disease pests which could have serious effects to agriculture, the following instruction must be followed for the materials listed:

**Live Plants.** All live plants and materials must be certified by the agriculture officials of the state of origin as pest-free. Contact the department of agriculture in your home state, especially if you are coming from California, before planning to bring any live plants.

**Fire Ants.** Special attention must be given to plants, soils, objects, pots, or materials from any states that have fire ants. Careful inspection and other measures must be taken to prevent the spread of these ants from Mississippi, Louisiana, Texas, and other states where fire ants exist.

**Brown Garden Snail.** Brown garden snails are prohibited in Virginia under the Nursery and Plant Pest Laws. Any plants or soil from areas known to be infested with these pests must be inspected and certified prior to shipment to Virginia.

**Poles and Logs.** All poles and logs must have the bark removed. Poles and logs from Maryland, Pennsylvania, Delaware, and from all states north and east of the aforementioned states, must be inspected and found free of gypsy moth egg masses and free of pine shoot beetles before moving these items to the jamboree. A federal quarantine has been enacted for the pine shoot beetle, *Tomicus piniperda*. Any regulated articles from regulated areas must be inspected and certified prior to movement. Regulated articles include (1) cut Christmas trees of pine, *Pinus spp.*; (2) logs and lumber with bark attached and tree stumps of pine; (3) nursery stock of pine; and (4) bark nuggets including bark chips of pine. As of April 1999, this quarantine affected about 100 counties in Illinois, Indiana, Maryland, Michigan, New York, Ohio, Pennsylvania, West Virginia, and Wisconsin.

**Cotton.** Cotton bolls (pods), cotton with seeds, cottonseed, and cotton plants must be treated by state, or by U.S. Department of Agriculture, officials before leaving the following states: Alabama, Arizona, Arkansas, California, Georgia, Louisiana, Nevada, New Mexico, Oklahoma, South Carolina, Texas, or other cotton-producing states or countries.



## Medical Requirements

Weather at the jamboree is very hot and humid. The jamboree activities are very strenuous. Therefore, it is *very important* that you drink plenty of water at the jamboree.

**Physical Examination.** All participants must submit certification of physical fitness on the official form, Personal Health and Medical Record Form, No. 67-34412. Maintenance of good health in a jamboree camp is of utmost importance, and it is with this objective in mind that the following must be enforced: (1) Participants will be expected to get a complete examination by a licensed health-care practitioner. (2) It is recommended that the examination take place not less than 15 days or more than six months before departure to the jamboree. (3) Participants will go through a medical screening upon arrival. In the event a leader is found medically unfit at this time, he or she cannot serve and must return home at his or her own expense.

**Immunizations.** Immunization requirements are based on recommendations of the U.S. Public Health Service. All participants must provide proof of immunization for tetanus within 10 years (since 1991). In addition, youth participants must provide verification of the following immunizations since birth: (1) measles, mumps, and rubella (MMR); (2) polio vaccine (oral or injection); (3) diphtheria, pertussis, and tetanus (DPT); and chicken pox. It is recommended, but not required, that immunizations for hepatitis B be considered.

**Exceptions to Immunization on Medical Grounds.** If there is a medical reason why you should not comply with vaccination requirements, obtain a statement to that effect from a physician. That statement must include specific reasons so it can be given full consideration by the jamboree medical staff.

**Medical Alert.** A national jamboree can be an exhausting experience. Many activities are physically strenuous and may result in special medical support consideration. Therefore, it is necessary that the medical staff be aware of participants who have certain physical conditions that may require special consideration. Conditions requiring a medical alert are:

1. Cardiac history
2. Diastolic blood pressure of 100 mmHg
3. Diabetes mellitus under treatment (with insulin or oral medication)
4. Marked obesity
5. Acute or severe bronchial asthma under treatment anytime during the past 24 months

6. Sickle-cell anemia, hemophilia, leukemia, or severe blood dyscrasia
7. HIV infection
8. Epileptic seizures having occurred within the past 12 months
9. Psychiatric illness under current treatment
10. Physical disability
11. Sleep apnea (Electrical sources are not available.)

In order to plan, prepare for, and support the participants having these medical conditions, an individual evaluation of each situation by the national medical team is required. There may be instances where proper medical support at the jamboree site is impossible. **Under such circumstances, participation may be denied.**

Any person with a severe physical disability, one of the conditions listed above, or with a reason to believe they may be medically unfit for jamboree participation must submit a request for a medical alert. Use a photocopy of both sides of the Personal Health and Medical Record Form, No. 67-34412, signed by a licensed health-care practitioner and send the copy to Boy Scouts of America, Jamboree Medical Officer, S208, 1325 West Walnut Hill Lane, P.O. Box 152079, Irving, TX 75015-2079.

Requests must be submitted by May 1, 2010.

## Insurance

Accident and sickness insurance will be provided to all those attending the 2010 National Scout Jamboree. The cost of this insurance is included as part of the national jamboree fee.

Coverage for registered members of the BSA will be effective from the time they leave their homes for direct travel to the jamboree site, during their stay at the jamboree, and from the jamboree site directly back home. Scouts and leaders who are registered for official pre- or post-jamboree tourist trips will be covered during that period as well. There is no coverage for any unofficial pre- or post-jamboree tourist trips. Scouts and leaders also are covered under this program during the time of their pre-jamboree training.

Scouts and leaders attending the jamboree as representatives of international Scout associations will be covered from their time of arrival in the United States to their arrival at the jamboree site, during their stay at the jamboree, and during the return to the point of departure from the United States. Jamboree staff members are also covered on the same basis.

Coverage is not applicable to employees of the BSA (National and local councils) while they are covered by any statutory workers' compensation policy.

**Note:** Scouts (including those from international Scout associations) will be covered under this insurance plan only when they are traveling to and from the jamboree in the United States and are participating in the jamboree as a group under supervision of their contingent leaders.

### Schedule of Benefits

- Accidental death, dismemberment, and loss of sight:

Life: \$10,000

Loss of limb(s), hand(s), foot or feet, eye(s), thumb, and/or index finger: up to \$20,000

**Note:** Only the largest amount will be paid for injuries resulting from any one accident.

- Physician, surgeon, hospital, and nurse's expenses for a covered injury: \$15,000
- Physician, surgeon, hospital, and nurse expenses for a covered sickness: \$7,500
- Dental expenses for a covered accident: \$7,500
- Return transportation expense for a covered injury or sickness upon the recommendation of a duly authorized medical authority: \$1,500
- Ambulance services for a covered injury or sickness upon the recommendation of a duly authorized medical authority: \$6,000
- Jamboree insurance will pay for accident or sickness " medical expenses up to \$300 regardless of any other benefits that you carry. Anything over \$300 should be covered by any other insurance you may have. The difference between what you collect from your insurance and the actual eligible expenses incurred will be covered by the jamboree insurance up to the policy limits of \$7,500 for illnesses and \$15,000 for accidents. If you have no other insurance, the jamboree insurance will cover all eligible expenses up to the policy limits.

### Claims

As in the case of all insurance policies, prompt notice of any loss insured against is necessary. Failure to comply with this requirement may cause annoyance, embarrassment, and under certain circumstances, denial of coverage by the insurance company. For your convenience, a claims representative of the insurance company will be on the jamboree site and may be contacted through the Enterprise Risk Management Group.

For claims made after the jamboree, contact Insurance and Risk Management, S402, at the national office.

### Transportation

Arrival and departure dates for jamboree participants will be:

Arrival: Monday, July 26, 7 A.M. to 4 P.M. (*Troops cannot arrive before 7 A.M.*)

Departure: Wednesday, August 4, 5:30 A.M. to noon. (Troops cannot depart before 5:30 A.M.—this means your airport departure must be after 9 A.M.)

Air terminals at Washington, D.C., are the official arrival and departure points. Dulles International Airport and Ronald Reagan Washington National Airport are the most convenient to the jamboree site. Jamboree staff representatives will be on hand to provide information and coordinate departures for the site. **All troop equipment and gateway material is the responsibility of the local council to ship by ground transportation.**

Each council must file a national tour permit with the regional service center for the jamboree trip. Refer to *Tours and Expeditions*, No. 33737C, for assistance in preparing your tour permit application.

If you are traveling in your own bus, which will stay at the site during the jamboree, dead storage will be provided at no cost. Vehicles *may not* be removed from dead storage before 5 A.M., August 4, 2010.

Councils will be asked to submit their request for transportation from terminals in Washington, D.C. (Dulles or Ronald Reagan Washington National Airport). If you are arriving by chartered bus, you will be asked to submit your arrival schedule.

The U.S. Army and Fort A.P. Hill have imposed extremely tight security measures for the 2010 National Scout Jamboree. This relates to not only Scouts, leaders, and staff arrivals but also personal equipment, luggage, and troop equipment entering the base.

While details are not yet finalized, it is conceivable that both arriving troops and equipment will be screened prior to entering Fort A.P. Hill. Troop equipment transported by trailers, trucks, and/or tractor trailers will be subject to search or screening prior to entering the fort. **THIS MEANS EQUIPMENT AND UNITS MUST ARRIVE AT THE SAME TIME—NO EXCEPTIONS.**

Troop equipment, displays, and personal luggage must accompany Scouts and leaders on arrival day. In all instances, contingent tour buses/vans and equipment trailers/trucks will need to go to a designated area for screening prior to arriving at the entrance of Fort A.P. Hill.

These changes have been prompted by increased security measures imposed by the United States Army, Fort A.P. Hill Garrison, in concert with the Boy Scouts of America. Full details on arrival/departure procedures will be communicated to council Scout executives by February 1, 2010.

## **Military Police and Public Safety Personnel**

Fort A.P. Hill is a military installation and is under the jurisdiction of military police (MP). Military police exercise the same jurisdiction as a U.S. marshal.

All adult leaders, staff members, youth participants, and visitors must obey military police instructions in traffic, safety, crowd control, parking, and directions. Do not argue or have a confrontation with the military police. If you have a complaint or concern about actions or directions given by the military police or public safety personnel, you must inform your supervisor as soon as possible after the incident.

Observe all speed limits, and be very careful of pedestrian traffic at all times in all locations within the boundaries of Fort A.P. Hill. The military police and public safety personnel are performing their assigned duty in support of the jamboree. Many of them are BSA volunteers and were youth members in Scouting programs. Remember, Scouts are courteous.

## **Council Caravans**

Councils are encouraged to organize caravans to the 2010 National Scout Jamboree for executive board members and key Scouters who desire to witness firsthand the excitement of this spectacular national event. Council volunteers interested in caravanning to the jamboree should be asked to contact the council service center to obtain information on their council's caravan. Council caravans must make a reservation with the National Jamboree Council Guest Reception Service at the national office.

Each council caravan of key Scouters will report to the Council Guest Reception Center upon arrival where they will be assigned a host who will conduct tours and arrange for visits with the council's jamboree contingent.

Advance arrangements may also be made with the National Jamboree Council Guest Reception Service for key council Scouters to eat lunch or dinner at a jamboree dining area.

Chartered units organizing their own trip to visit the jamboree must obtain a national tour permit application from their council service center. On receipt of the completed application, councils will send a copy to National Jamboree Council Guest Reception Service. All units must follow the rules set forth on the national tour permit application.

These units will not be able to participate in jamboree program but can attend arena shows.

## **Telephone Communications**

Because of the limited facilities for telephone communication at the jamboree site, all incoming telephone calls to persons participating in the jamboree will be handled on an *emergency basis* only as follows:

- All emergency phone calls must be made to a number which will be sent to councils before the jamboree.
- Messages will then be delivered to the person's subcamp headquarters.
- Persons will then return calls—if necessary—from pay telephones at the jamboree site.

It is important that someone be appointed to receive emergency calls that may come into the council service center during the jamboree.

Council service centers must have on file the names, addresses, and phone numbers of parents or guardians of each youth member and spouse or relative of each unit leader and staff member to contact in case of an emergency. The home and business telephone numbers must also be on file.

Each council is asked to appoint a person or persons to be responsible for handling emergencies day and night during the jamboree. Their names and phone numbers should be sent to the regional jamboree coordinator at the regional service center. Your jamboree unit leaders must have these names and phone numbers and the name and phone numbers of the key persons to contact in the council.

## **Lost and Found**

A lost-and-found department will be located near the jamboree headquarters and in each subcamp headquarters.

Persons seeking lost articles should report to their subcamp lost-and-found area and fill out an identification card describing the missing item(s). A check will then be made to determine whether the missing material has been turned in to one of the other subcamp lost-and-found stations or the jamboree headquarters location.

To guard against the loss of valuables, Scouts and leaders should:

- Mark uniforms and personal equipment with their name, home address, jamboree subcamp number, and their jamboree troop number.
- Store equipment in a lock box or personal pack when not in use (especially when leaving camp).
- If you find any item at the jamboree, take it to the nearest Lost and Found. Mark the item with your name, troop number, and where it was found.

## Trading Posts

Three jamboree trading posts will be operated in convenient locations.

The following services and types of items will be available in each trading post:

**Souvenirs.** An attractive line of jamboree souvenirs and other materials will be available to send or take back home.

**Sundries.** A varied assortment of hardware, drug, and miscellaneous items will be on sale.

**Snacks.** Soft drinks, milk, candy, and light meals will be available.

**Photo Service.** Film, flashbulbs, and other photographic supplies will be on sale. Printing and developing will be a special service in this department.

**Prices.** Prices charged for all merchandise and services at jamboree trading posts will be similar to the prevailing prices of comparable merchandise in cities and towns in the area.

A fully stocked Scout shop will be located near Trading Post B, across from jamboree headquarters. Uniforms, camp equipment, and many Supply Group items will be available.

## Living Quarters Near the Jamboree

A policy has been established that there shall be no visiting units of the Boy Scouts of America in living quarters adjacent to the jamboree area. This means that no hotels, motels, military facilities, public camping places, or local council camps within 50 miles of the jamboree site will be available to visiting units for living purposes.

## Accommodations at the Jamboree

Motel and hotel facilities are available near the jamboree site for jamboree family visitors. Light meals will be available at the trading posts.

## Visitors

The jamboree will be open to visitors every day, beginning with Wednesday, July 27, and continuing through Tuesday, August 3. Hours are from 9 A.M. to 5 P.M. Visitors will be permitted to stay until 11 P.M. only in order to attend the arena show.

On entering the jamboree site, guests will be directed to the public reception location. Here they will receive directions to regions, subcamps, or activity areas.

### Locating Friends and Relatives

The Public Reception Service will assist visitors in locating friends and relatives.

An alphabetical directory of all jamboree participants will be available through the Public Reception Service, along with a listing of each participant's troop number, subcamp, regional camp, or jamboree service. Each subcamp and regional camp headquarters will also maintain a roster of its boy and adult leader jamboree participants.

### Reception of Guests in Troops

Several thousand visitors will receive a lasting impression of Scouting from their visit to the jamboree. In view of this, every Scout and Scouter must exemplify Scouting's highest ideals and traditions at all times.

Troop guests should be directed first to the troop leader in charge, who will then escort the visitors to friends and relatives. Subcamps are quite a distance from Visitor Parking. It is recommended that troops plan a visitor day and meet their guests near the parking lot.

Unusual stories about jamboree troop visitors may merit placement in the news media, and troop leaders are encouraged to submit such information to the communications office at the jamboree.

### International Visitors

Scouts and leaders from other Scout associations around the world will participate in the jamboree. International Scouts will be assimilated into council jamboree units, while international leaders may be used to supplement unit, subcamp, or regional staff members. Contact your regional jamboree coordinator to invite international visitors to camp with your unit.

## **Policy on Smoking, Alcohol, or Drugs**

Whenever a member of the Boy Scouts of America appears before the public, especially in uniform, that member is literally on parade before the people of America. This will be especially true while young people and their leaders are headed for the jamboree, at the jamboree, or returning home. All of us must make sure that the conduct of each youth and adult is above reproach. This places a great responsibility on all leaders—youth and adults alike.

The Boy Scouts of America prohibits the use of alcoholic beverages and controlled substances at encampments or activities on property owned and/or operated by the Boy Scouts of America, or at any activity involving participation of youth members.

Adult leaders should support the attitude that young adults are better off without tobacco. The use of tobacco products is illegal and will not be allowed for any individual under the age of 18.



## Staff Statement of Understanding and Code of Conduct

**Statement of Understanding:** All staff, youth and adult, are selected to represent their local councils based on their qualifications in character, camping skills, physical and personal fitness, and leadership qualities. By signing the letter of appointment, all adult staff members as well as youth staff members and their parents or guardians agree to the conditions of the Code of Conduct and Statement of Understanding as a condition of participation. It is with the further understanding that serious misconduct or infraction of rules and regulations may result in expulsion, at the staff member's expense, from the jamboree. Ultimately, each staff member is responsible for his or her own behavior, and only when necessary will the procedure be invoked to send the staff member home from the jamboree.

### **All staff members are expected to abide by the Code of Conduct as follows:**

1. The Scout Oath and Law will be my guide throughout the jamboree.
2. I will set a good example by keeping myself neatly dressed and presentable. (The official Scout uniform and jamboree identifying items are the only acceptable apparel.)
3. I will attend all required training and scheduled programs and participate as required in cooperation with other staff members and leadership.
4. In consideration of other staff members, I agree to follow the bedtime and sleep schedule of the unit, unless otherwise directed by the staff leader due to requirements of the jamboree program.
5. I will be responsible for keeping my quarters and personal gear labeled, clean, and neat. I will adhere to all jamboree recycling policies and regulations. I will do my share to prevent littering of the jamboree grounds.
6. I understand that the purchase, possession, or consumption of alcoholic beverages or illegal drugs by any youth member is prohibited. This standard shall apply to all who attend the jamboree.
7. Serious, disruptive, and/or repetitive behavior violations by youth, including use of tobacco, cheating, stealing, dishonesty, swearing, fighting, and cursing, may result in expulsion from the jamboree or serious disciplinary action and loss of privileges. The jamboree director *must be contacted* for the expulsion procedure to be invoked. *There are no exceptions.*
8. I understand that gambling of any form is prohibited.
9. I understand that possession of lasers of any type, and possession or detonation of fireworks is prohibited.
10. I will demonstrate respect for U.S. Army and jamboree property and be personally responsible for any loss, breakage, or vandalism of property as a result of my actions.
11. Neither the staff leader nor the Jamboree Division, BSA, will be responsible for loss, breakage, or theft of personal items. I will label all my personal items and check items of value at the direction of unit leaders. Theft will result in immediate expulsion.
12. While working in my staff position and other activities, I will obey the safety rules and instructions of all supervisors and staff members and will follow the *Guide to Safe Scouting*.
13. In accordance with BSA policies and U.S., local, and state laws, staff members are prohibited from having firearms and weapons in their possession.
14. Staff members will be guided by the Scout Oath and Scout Law and will obey all U.S., local, and state laws.
15. All staff members must receive Youth Protection training through their local councils and follow the guidelines therein prior to, during, and after the jamboree.
16. Hazing has no place in Scouting. Nor do running the gauntlet, belt lines, or similar physical punishment. Adult staff and older youth must prevent any youth from being "initiated" into the troop with a hazing activity.
17. Adult staff members must exercise the good judgment to avoid trading souvenirs or patches with youth members in Scouting. Youth members may trade with youth members. Adult leaders may trade only with other adults 18 years of age or older.
18. Adult staff members must instruct youth to avoid confrontation with groups, demonstrators, or hecklers and must assume a passive reaction to name-calling from individuals or groups. Units or groups must be removed from the area of potential conflict immediately.
19. Any violation of this code may result in expulsion from the jamboree at the participant's own expense. All decisions will be subject to the discretion of the jamboree director and will be final.
20. Military police and public safety officers have the authority and powers of U.S. marshals; their orders and instructions are to be obeyed. Any complaints or concerns should be taken to your staff leader as soon as possible after the incident.



## Personal Equipment

The national jamboree committee is anxious to reduce excessive expenditure for jamboree uniforms. Those specified here are the same as are used by the participants in regular unit activities.

### Scouts and Leaders

Official national jamboree uniform:

- Scout shorts
- Scout visored cap or jamboree cap
- Scout shirts, short-sleeve casual
- Scout khaki web or leather belt
- Scout socks or stockings (official red top)
- Jamboree neckerchief
- Jamboree neckerchief slide
- Water-repellent jacket (jamboree jacket emblem optional)

### Activities Uniform

The activities uniform for youth and leaders will be a jamboree T-shirt, Scout shorts, Scout socks or stockings, Scout visored cap, or jamboree cap.

### Travel Uniform

While aboard planes, trains, buses, or autos en route, youth and leaders must wear the official national jamboree uniform.

### Proper Uniforming

Absolutely no variations in the official uniforms are to be made.

Absolutely no hats, helmets, or caps other than those listed as the official national uniform shall be worn en route to the jamboree.

T-shirts may also be worn in troop areas, but are not proper wear at special functions.

### Official Neckerchiefs and Emblems

Two jamboree emblems and one neckerchief will be issued to approved youth and their leaders. The first emblem for each individual will be sent to the council upon receipt of the \$100 per person national reservation fee. This is to be sent to the national Jamboree Registration Service on the form pro-

vided on or *before* February 1, 2009. They are to be presented to participants and may be worn on the uniform immediately. The second emblem will be sent to the council upon receipt of the final national payment, which is due on or before February 1, 2010. The neckerchief will be distributed at the jamboree. Additional quantities of the emblem **must** be ordered in advance from the Supply Group. Additional neckerchiefs can be secured at the jamboree trading posts.

### Required Personal Camping Equipment

- 1 Day pack
- 1 Duffel bag—for carrying and storage of bulky items
- 2 Blankets or 1 sleeping bag, or combination of both
- 1 Air mattress
- 1 Ground cloth
- 1 Poncho
- Extra uniform parts (in addition to those parts of official uniform listed)
- 3 Sets of underwear
- Extra stockings
- Laundry bag, recommended for use in duffel bag to hold soiled clothing
- 2 Sleeping clothing
- 1 Swimming suit
- 1 Pair rubber-soled shoes
- 1 Eating kit containing 1 knife, 1 fork, and 1 spoon
- 1 Toilet kit containing soap in container, comb, toothbrush, metal mirror, washcloth, toothpaste, and deodorant
- 1 Plastic washbasin
- Laundry materials (detergent in small plastic bag)
- 2 Hand towels
- 2 Bath towels
- 1 Sewing kit
- 1 Flashlight (No flame-type lights will be permitted.)
- 1 Scout knife
- 1 Bible, Testament, or prayer book—according to faith
- 1 Canteen or plastic water bottle
- 1 Insect repellent (non-aerosol)

## Personal Equipment (Optional)

- Watch
- Notebook, pen, pencil
- Camera, film
- Drinking cup, collapsible
- Shaving gear (if needed)
- Musical instrument
- Shoelaces, extra pair
- Air pillow (small)
- Boy Scout Handbook
- Fieldbook
- Scout Songbook
- Duffel-bag lock
- Wallet
- Sunglasses
- Utility bag for carrying items needed on plane, train, or bus

## Patrol Equipment

- 1 First-aid kit
- \*4 Two-person tents with poles and pegs
- \*1 Dining fly with poles and pegs (including ridge pole)
  - 1 Patrol flag on staff—homemade
  - 1 Patrol repair kit—sharpening stone, string, thin wire, needles, thread, and safety pins
  - 1 Patrol food box—constructed not only to provide for food storage but for use as a kitchen worktable
- \*1 Trail Chef cook kit containing:
  - 4 Pots
  - 2 Frying pans
  - 10 Cups
  - 10 Plates
  - 10 Bowls
- \*2 Stoves (two-burner) propane
  - 1 Griddle, aluminum or magnesium

- \*1 Chef's tool kit containing:
  - 1 Carving knife
  - 1 Large spoon
  - 1 Large fork
  - 1 Ladle
  - 1 Paring knife
  - 1 Steam pan
  - 1 Pancake turner or spatula
  - 1 Potato peeler
  - 1 Mechanical can opener
- \*1 Chef's outfit consisting of:
  - \*10 Aprons (disposable) flame retardant
  - \*2 Pairs hot-pot tongs
  - \*2 Pairs hot-pot mittens or gloves
- 2 Sets of eating gear for guests, consisting of a fork, a knife, and a spoon
- \*5 Containers with lids, nonbreakable, for sugar, salt, etc.
- \*2 64-ounce pitchers/decanter, nonbreakable, for liquids
  - 1 Sugar dispenser
  - 1 Set of salt and pepper shakers
- \*1 Laundry bucket
- \*2 Water carriers
  - 1 Waterproof match container with matches
- \*1 Large aluminum pot for heating water
- \*2 Scouring pads or copper wire with soap-processed cleaning cloth (such as mirror cloth)
  - \* Handi Wipes
- 1 Patrol table—see design and materials list on page 30. (Also, refer to "Special Notice to All Local Councils" on page 27.)
  - Aluminum foil (heavy duty)
  - \* Plastic table cover for 8-foot table
- 1 3-inch kitchen funnel
- 1 Fruit juice can opener
- \*1 3-gallon water/punch cooler (Note: If you do not purchase the patrol equipment package, you must provide your own water coolers.)

---

\*Items provided in Supply Group Equipment Package.

## Troop Equipment

- \*1 Dining fly with poles and pegs (including ridge pole)
- \*4 Leaders' (two-man) tents with poles and pegs
- \*1 Storage tent with poles and pegs—two-man size
- \*1 Water carrier (for washing hands)
- \*1 Lantern (electric) with extra battery
- 1 Bulletin board
- 1 U.S. flag, parade size, 4 $\frac{1}{3}$ -by-5 $\frac{1}{2}$ -foot
- 1 Flagstaff, 8-foot, with emblem
- 1 Flag-carrying sling
- 1 Jamboree troop flag to be flown on display flagpole  
(Troop flags, size 4 $\frac{1}{3}$ -by-5 $\frac{1}{2}$ -foot, with lettering must be ordered at least three months before the jamboree.)
- Materials for gateways
- 1 Equipment box containing:
  - \*4 Hammers (for patrol use)
    - \*Assorted nails
    - \*Pliers
    - \*Roll of light wire
    - \*Ball of light cord
    - \*Screwdriver
    - \*Thumbtacks
  - \*4 Felt pens
  - \*Laundry bucket
  - \*Table cover
  - Grommet-setting kit
  - Tent repair kit
- 1 Crescent wrench
- \*1 Hot beverage pot
- \*1 Shovel
- \*1 Bow saw, 21"
- \*1 Extra blade for bow saw

**Note:** The Boy Scouts of America is dedicated to safety in camping and has long been a leader in promoting the use of flame-retardant tents and flies. In order to ensure the highest possible level of fire safety at the 2010 National Scout Jamboree, all tents and flies used at the jamboree, for any purpose, must be of flame-retardant materials which meets CPAI-84 specifications. Supply Group equipment meets these specifications. (CPAI is the Canvas Products Association International.)

---

*\*Items provided in Supply Group Equipment Package.*

## Special Notice to All Local Councils

In 1997, Fort A.P. Hill, Directorate of Public Works, notified the Boy Scouts of America that because of limited landfill availability in Caroline County, Virginia, the following items must be removed from the site by the jamboree contingent:

- Displays
- Gateways
- Stage props
- Patrol picnic tables
- Patrol food chests



2010 National Scout Jamboree

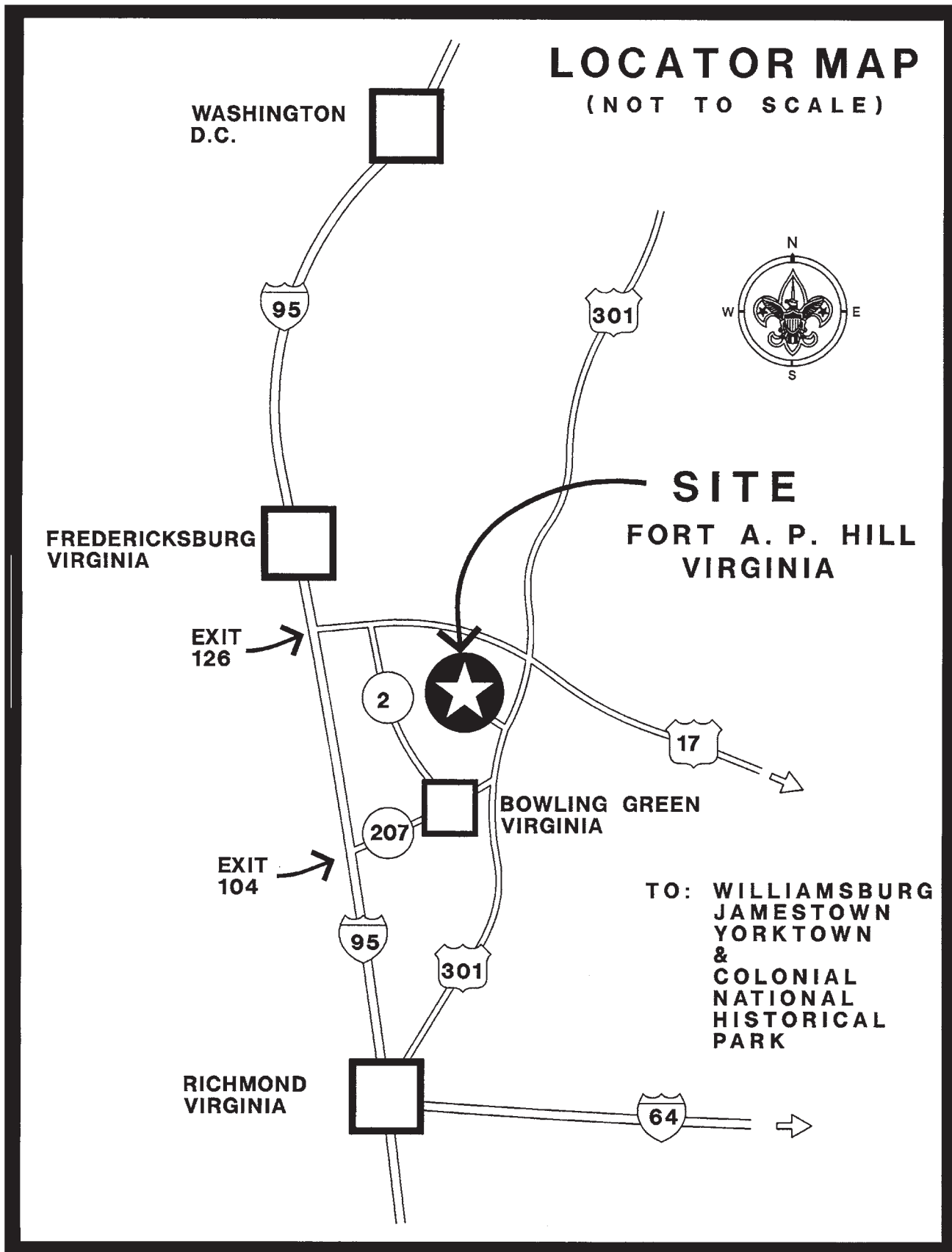

## (Sample Only)

### 2010 National Scout Jamboree Local Council Jamboree Information Sheet

**DATES** (Month) (Date)—July \_\_\_\_\_, 2010 (You might want to list here your council departure date and return date.)

**TRAVEL PLANS** The \_\_\_\_\_ Council jamboree contingent will leave \_\_\_\_\_ on \_\_\_\_\_ and fly to Washington, D.C. We will travel to Colonial Williamsburg and other points of historic interest.

While in Washington, D.C., ample time will be allowed to tour the Smithsonian Institution, the White House, and many more of the federal offices, such as the FBI and the Capitol. We will camp at the jamboree until the morning of August 4. On August \_\_\_\_\_ we will return to Washington, D.C., for the return flight to \_\_\_\_\_.

**ORGANIZATION** The jamboree is open to all who are qualified on a first-come basis. After our troops have been filled, a stand-by list of alternates will be established. Scouts will be assigned to a jamboree troop consisting of 36 Scouts and four adult leaders. You will be a member of a patrol within the troop. The council contingent will consist of \_\_\_\_\_ troops.

**TOTAL COST** \$\_\_\_\_\_ for Scouts—\$\_\_\_\_\_ for leaders

PAYMENT SCHEDULE:	Scout Fees	Leader Fees
	Reservation fee \$_____	with application \$_____
	Second payment \$_____	August 1, 2009 \$_____
	Final payment \$_____	February 1, 2010 \$_____

**FEE INCLUDES** The jamboree fee covers all transportation, tours, admission fees, meals, lodging, and patrol and troop equipment, as well as insurance. Your fee also covers the training camp before the jamboree. The only additional expense will be your personal equipment, uniforms, and spending money. The fee is based on an airfare of \$\_\_\_\_\_. If this should be increased, we may have to increase the total jamboree fee accordingly.

**REFUND POLICY** If you sign up for the jamboree and then find that you cannot attend, you will receive a full refund from the \_\_\_\_\_ Council only if there is an alternate to take your place.

In the event there is not an alternate, a partial refund will be made. This includes the fees you have paid to date, less any expenses related to contractual agreements made on your behalf.

MATERIALS LIST

QTY	MEMBER TYPE	DIMENSION	NOTES
2	MEMBER A	2 x 4 x 2'-2 1/2"	
4	MEMBER B	2 x 4 x 3'-2 3/8"	
2	MEMBER C	2 x 4 x 2'-2 3/8"	
1	MEMBER D	2 x 4 x 4'-3 1/2"	
2	MEMBER E	2 x 6 x 4'-10 3/4"	
5	TABLE TOP	1 x 6 x 8'	
3	TABLE BRACE	2 x 2 x 2'-2 1/2"	
2	TABLE CLEAT	2 x 2 x 2'-2 1/2"	
4	BENCH SEAT	1 x 6 x 8'	
6	BENCH BRACE	2 x 2 x 8 3/4"	
4	BENCH CLEAT	2 x 2 x 8 3/4"	
2	BENCH FACIA	2 x 4 x 8'	
32	CARRIAGE BOLT ASSEMBLY	3 1/2" x 3/8"	W/ 2 WASHERS 1 NUT
18	WOOD SCREW, GALV.	1 1/2"	COUNTERSUNK
60	WOOD SCREW, GALV.	1 3/4"	COUNTERSUNK
14	WOOD SCREW, GALV.	2 1/4"	COUNTERSUNK

NOTES:

1. ALL BENCH & TABLE CLEATS & BRACES TO BE RECESSED 1" FROM ANY EXPOSED EDGE & TO HAVE A 3/4" CHAMFER.

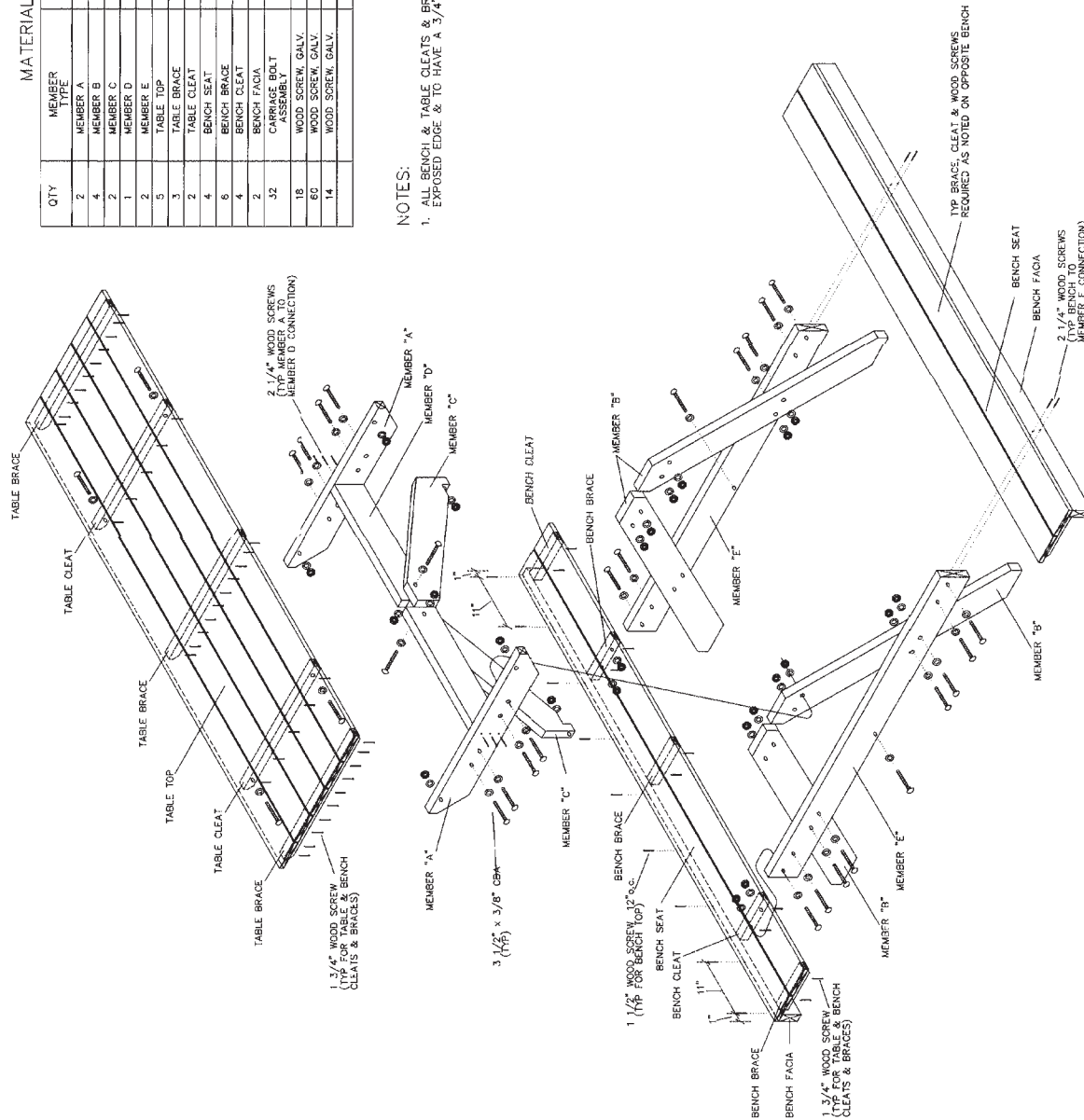

NOT TO SCALE

DWG. NO: 01J-PT 2A  
DATE: DEC. 8, 1995



STUDY BY: TH / BLH  
DRAWN/CK'D BY: J.C.S. / JBM  
"Scout Seating... by design"

PATROL TABLE  
EXPLODED VIEW

2005 NATIONAL SCOUT JAMBOREE  
FORT A. P. HILL, VIRGINIA

ENGINEERING SERVICE  
BOY SCOUTS OF AMERICA  
1325 W. Virginia Ave.  
Irving, Texas 75015-2078

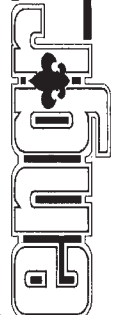

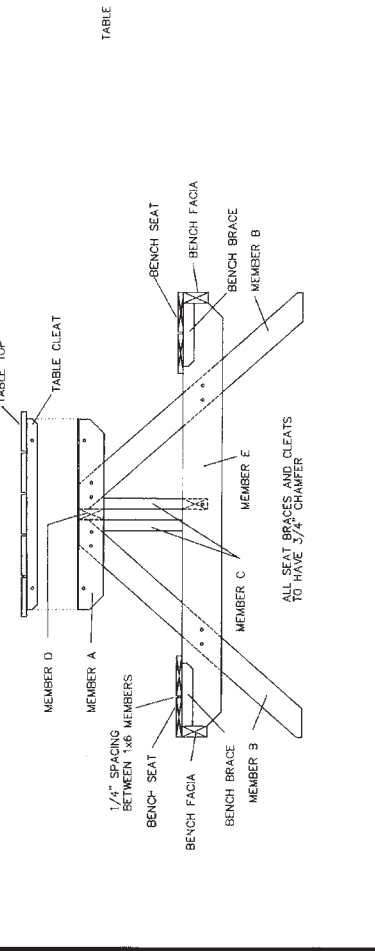
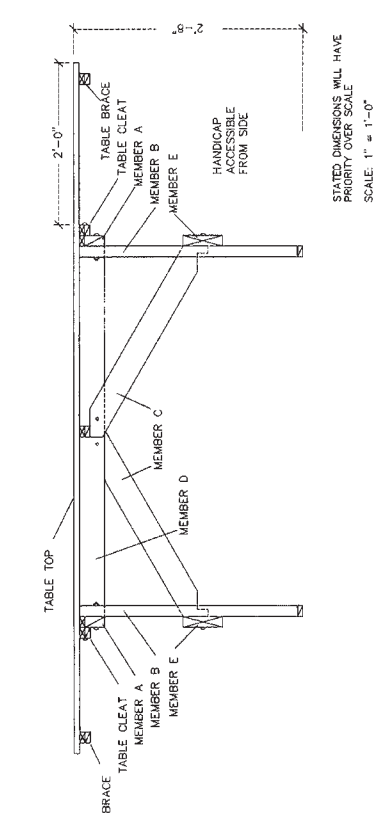
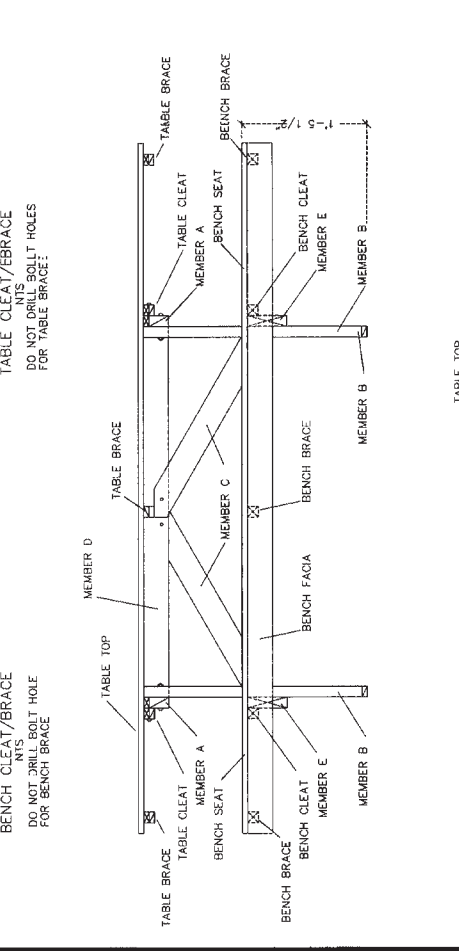
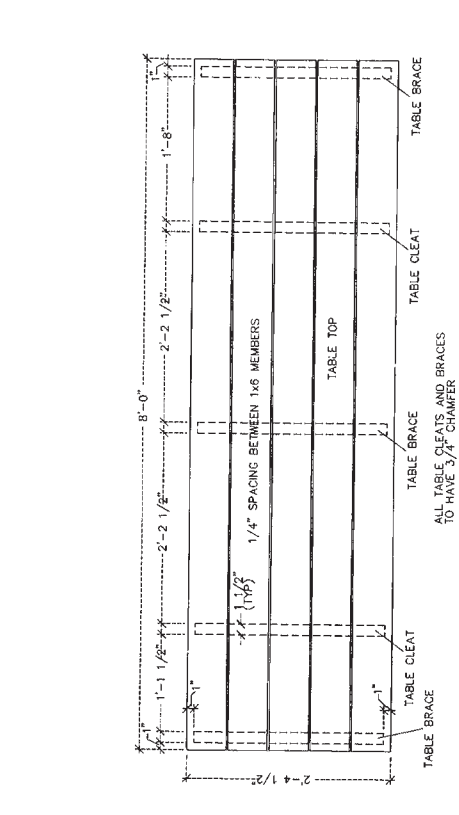
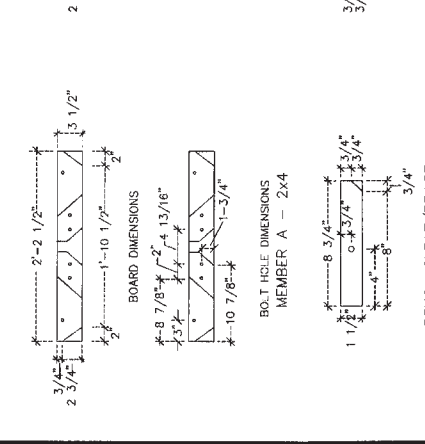
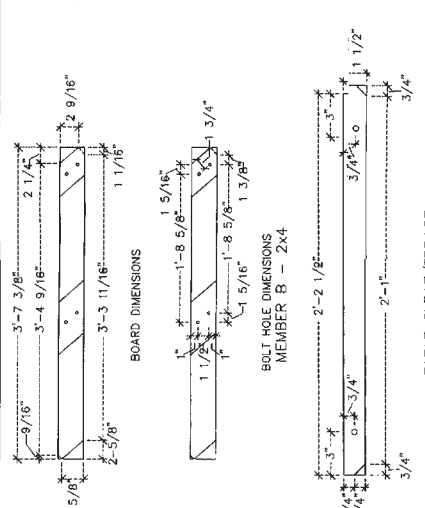
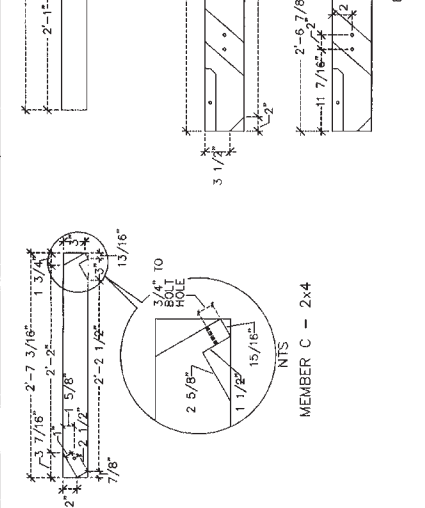
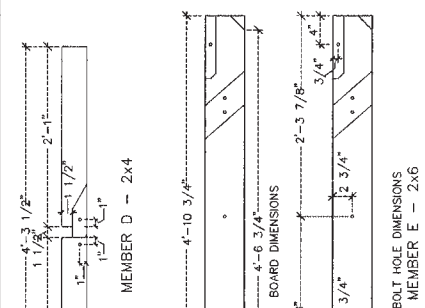

STATED DIMENSIONS WILL HAVE PRIORITY OVER SCALE.

SCALE: 1" = 1'-0"

STUDY BY: TH. / BL.H.  
DRAWN/CHKD. BY: J.C.S. / J.B.H.

2005 NATIONAL SCOUT JAMBOREE  
FORT A. P. HILL, VIRGINIA

ENGINEERING SERVICE  
BOX SCOUTS OF AMERICA  
1325 W. Walnut Hill Lane  
Irving, Texas 75015-2073

Patrol Table  
Orthographic Views



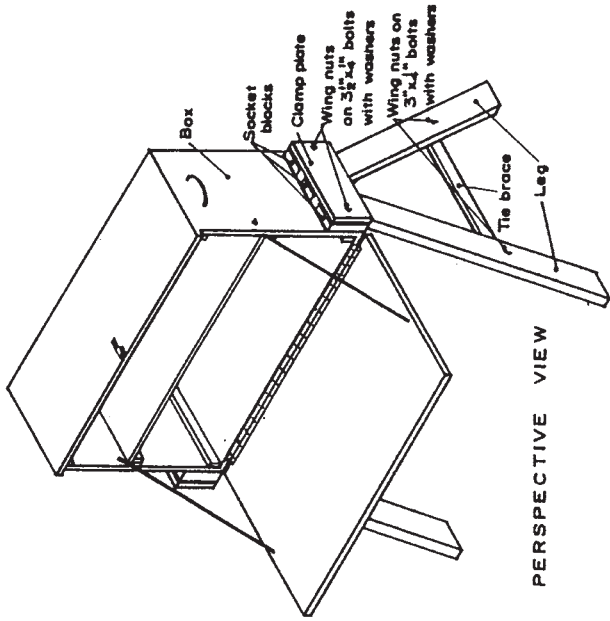
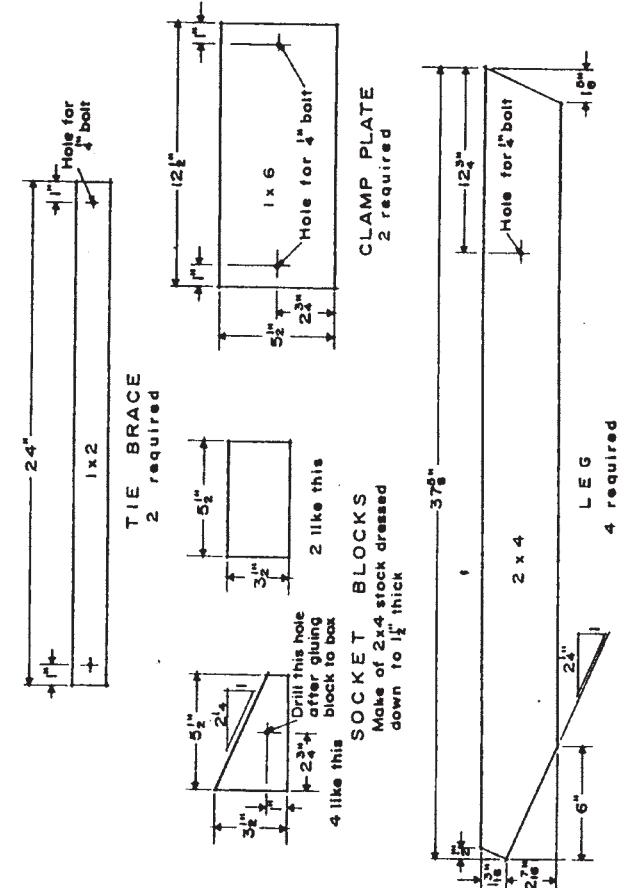
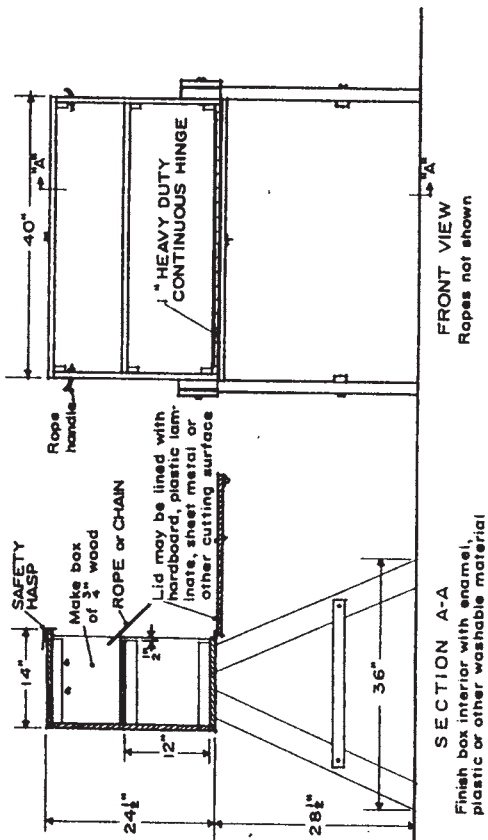

PERSPECTIVE VIEW

ASSEMBLY:

1. Attach tie braces to legs but do not tighten wing nuts.
2. Loosen wing nuts on clamp plates (plates, once installed, remain on box).
3. Insert legs in sockets and tighten wing nuts.
4. Tighten tie brace nuts.

To disassemble, reverse above procedure.  
Store legs and braces inside box.

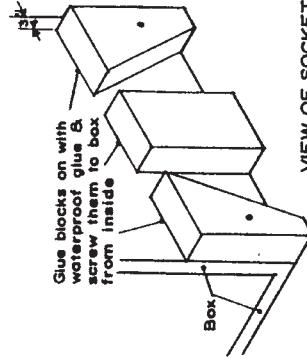

VIEW OF SOCKET BLOCKS IN PLACE ON BOX END



ENGINEERING SERVICE  
BOY SCOUTS OF AMERICA  
1335 West Walnut Hill Lane  
Irving, Texas 75015-2079

CAMPSITE FOOD CHEST

DESIGN  
STANDARD

44